



SERIES  
**18C/25C**  
TEMPERATURE/PROCESS  
CONTROLLER

---



*Instruction Manual  
(Basic Operations)*

## Introduction

Congratulations on your purchase of an Athena Series 18C or 25C Temperature/Process Controller. It is designed for ease of use and reliability wherever accurate control is required.

After following the instructions for installation, simply step through and set your operating parameters using the controller's easy menu system. The instrument may then be automatically or manually tuned to your process for optimum setpoint control. A Quick-Start Reference Card is attached to the back of the instruction manual for experienced users of PID controllers.

As you look through this manual, you will notice blue italicized text appearing in the margins and adjacent to operating information. These notes impart important information about the controller and may answer questions you may have about its setup or operation. If you still have questions or require any assistance, please contact your Athena representative or call technical support at 1-800-782-6776. Outside the U.S., please call 610-828-2490.

## Precautions

After unpacking, inspect the instrument for any physical damage that may have occurred in shipping. Save all packing materials and report any damage to the carrier immediately.

## Features

Field-Selectable Thermocouple, RTD, Current or Voltage Input  
On/Off Through Full PID Operation  
Autotuning - Heat or Cool  
Eight-Segment Ramp/Soak  
On/Off Output with Adjustable Hysteresis and Deadband  
Dual Output Capability  
Field-Configurable Process or Deviation Alarms  
Bumpless, Auto-Manual Transfer  
NEMA 4X Front Panel, "Watertight"  
Dual 4-Digit (0.36"), 7-Segment Alphanumeric Display  
Selectable Ramp to Setpoint  
Alarm Inhibit  
Loop Break Alarm Capability  
Available Options Include Serial Communications, Contact/  
Digital Input, Remote Analog Setpoint, Transducer Excitation,  
Auxiliary Output, Dual Alarms, or Electromechanical Relay  
Alarm.  
Approvals: CE-compliant; UL and cUL pending

## Safety Warning



In addition to presenting a potential fire hazard, high voltage and high temperature can damage equipment and cause severe injury or death. When installing or using this instrument, follow all instructions carefully and use approved safety controls. Electrical connections and wiring should be performed only by suitably trained personnel.

Do not locate this instrument where it is subject to excessive shock, vibration, dirt, moisture, oil, or other liquids. The safe operating temperature range for this unit is 32°F to 140°F (0°C to 60°C).

This unit has been tested and found to be compliant with “NEMA Type 4X Enclosure - For Indoor Use Only.” When properly installed, this controller will maintain the integrity of a NEMA enclosure and remain “Watertight.” This rating is only applicable when the controller is properly installed into a suitably rated NEMA Type 4X housing.



## Table of Contents

*For information and operating instructions related to installed options and digital communications, refer to the Series C options and communications manual supplied with your controller.*

<b>Installation</b>	6
Dimensions and Mounting	7
Wiring	8
Output Types	11
<b>Operation</b>	13
Front Panel Controls	13
Power On	14
Security Levels	15
Operating Modes	17
Menu System Overview	19
Initial Setup Sequence	24
<b>Parameter/Menu Descriptions</b>	26
Input Menu	27
Temperature Input	29
Process (Linear) Input	29
Display Menu	30
Output Menu	31
PID Output and Control Menus	32
On/Off Output and Control Menus	34
Alarm Outputs	35
Autotune Damping	37
Ramp and Soak Menu	38
Supervisor Menu	41
Calibration Menu	42
Options Menu	42
<b>AutoTuning</b>	43
<b>Manual Tuning</b>	45
<b>Error Codes</b>	47
<b>Technical Specifications</b>	48
<b>Ordering Codes</b>	52
<b>Recalibration Procedures</b>	53
<b>Quick – Helps</b>	54
<b>Warranty/Repairs</b>	57
<b>Glossary</b>	61
<b>Quick Setup Instructions</b>	65
	5

# Installation

## Unpacking and Inspection

Measurements between centerlines of panel cutouts are the minimum recommended.

1. Inspect shipping carton for obvious signs of mishandling.
2. After removing the controller from the shipping carton, inspect it carefully for damage. Never attempt to install and use a damaged unit.
3. Verify that the ordering code number indicated on the side of the controller matches what was ordered.

**Figure 1.**  
**Recommended Panel Layout for Multiple Controllers**

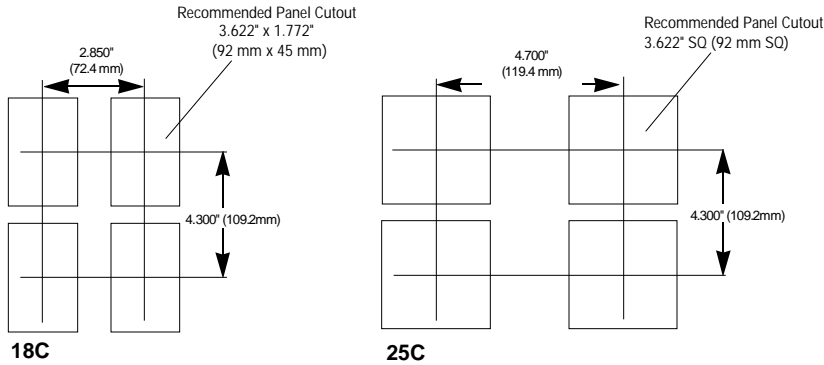

## Dimensions

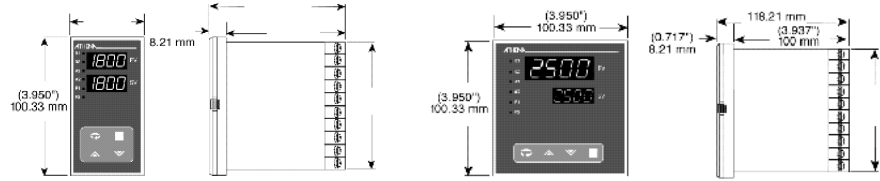
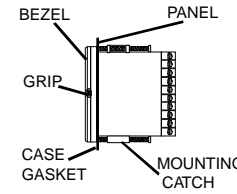

**Figure 2. Case Dimensions**

## Mounting

When properly installed through a NEMA enclosure, the integrity of the enclosure will be maintained and will remain "Watertight."

If the unit has been shipped with mounting catches already installed in the top and bottom slots in the case housing, they must be removed to allow insertion of the controller into the panel

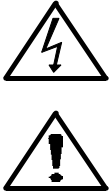

**Figure 3.**  
**Mechanical Components**

Remove static-protective wrapping material from the instrument. Avoid inducing static charges to controller while handling and mounting. Insert the controller into the panel cutout from the front of the panel. Place the mounting catches into the appropriate mounting slots at the top and bottom of the case housing and tighten the mounting screws to secure the controller firmly to the panel.

Note: For some panels, it may be necessary to first remove the controller chassis from the case housing to access the mounting catches from the inside. Press the grips on each side of the bezel firmly until the tabs release and slide the chassis out of the housing. Install the housing and secure it with the mounting screws to the panel. To re-insert the controller chassis back into its case, press both bezel grips simultaneously and slide the controller into the housing until the tabs engage.

## Wiring



**IMPORTANT:** All electrical wiring connections should be made only by trained personnel, and in strict accordance with the National Electrical Code and local regulations.

The Series C controller has built-in circuitry to reduce the effects of electrical noise (RFI) from various sources. However, power and signal wires should always be kept separate. We recommend separating connecting wires into bundles: power; signal; alarms; and outputs. These bundles should then be routed through individual conduits. Shielded sensor cables should always be terminated at one end only.

If additional RFI attenuation is required, noise suppression devices such as an R.C. snubber at the external noise source may be used. If you wish, you may order this suppressor directly from Athena, part number 235Z005U01.

**Figure 4. Contact Identification**

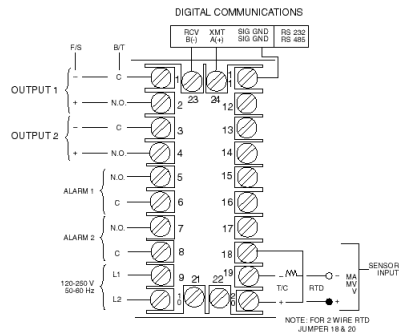

## Wiring

*Thermocouple circuit resistance should not exceed 100 ohms for rated accuracy; errors will occur at higher resistance values. If shielded thermocouple wire is used, terminate the shield only at one end.*

**Figure 5. Thermocouple Input Wiring**

Make sure that you are using the appropriate thermocouple and extension wire. Connect the negative lead (generally colored red in ISA-type thermocouples) to contact #19; connect the positive lead to contact #20. Extension wires must be the same polarity as the thermocouple.

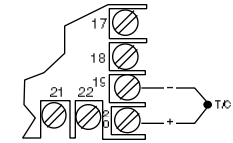

**Figure 6. RTD Wiring**

The Series C accepts input from 2- or 3-wire, 100 ohm platinum resistance temperature detectors (RTDs). Connect 2-wire RTDs to contacts #19 and #20, with a jumper across contacts #18 and #20. Keep leads short and use heavy gauge copper extension wire, if necessary, to minimize lead resistance. For long runs, 3-wire RTDs should be used.

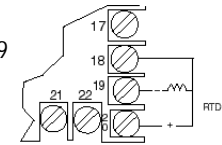

Note: For 2-Wire RTD  
Jumper 18 & 20

## Wiring

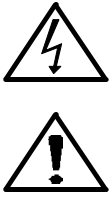

**Figure 7. Process and Linear Input Wiring**

Voltage Inputs: Connect the positive voltage input to contact #20; the negative input to contact #19. Current Inputs: Connect the positive current input to contact #20; the negative input to contact #19.

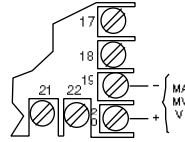

The Series C power supply accepts 100 to 250 Vac and 100 to 250 Vdc line power without any switch settings or polarity considerations. All connections should be made in accordance with the National Electrical Code and local regulations, using only NEC Class 1 wiring for all power terminals.

It is advisable, but not necessary, to fuse one leg of the incoming power line, contact #9 or #10, with a 2AG, 0.5 amp rated fuse. *Be sure that only instrument power input is fused — not power to the load.*

**Figure 8. Power Wiring Connection**

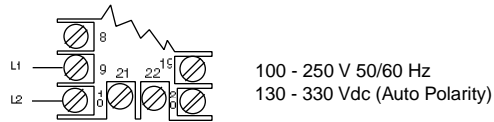

## Output Types

*The Type "B" output is a mechanical device and subject to wear. To extend the life of the relay, set the Cycle Time for the relay output to the longest duration that still affords good control.*

When you ordered your Series C controller specific output types were specified, designated as "B", "E", "F", "G", "S", "T" or "Y". You also had the option of configuring your controller with either one or two output actions. The numbers below are suggested for most typical applications.

For Control Output Type —	Select Cycle Time (in seconds)
B	>15
E	0.2
F	0.2
G	0.2
S	0.2
T	15*
Y	>15

*\*\*T\* outputs directly driving non-inductive loads (small heaters) can have cycle times as low as 0.2 seconds.*

## Output Types

Output Type	Description
B	5 A (120/240 Vac) relay, normally open, used for switching resistive loads. If relays or solenoids are to be driven, select the "T" output. If a "B" output is selected, order snubber network 235Z005U01.
E	0-20 mA
F	4-20 mA, full output to load with 500 ohm impedance max. (suppressed).
G	High impedance 'F' (700 ohms).
S	20 Vdc pulsed output for solid-state relays.
T	1 A @ 120/240 Vac, solid-state relay, zero voltage-switched and optically isolated from drive signal. Only resistive loads to 1A may be controlled directly. Larger loads may be controlled using an external contactor.
Y	5 A (120/240 Vac) relay, but normally closed (output 2 only).

## Operation

Figure 9. Front Panel Controls and Indicators

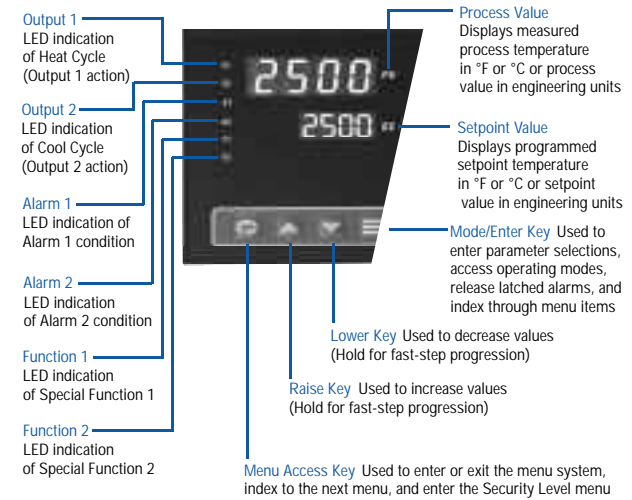

After mounting and wiring your controller, you are ready to set the parameter values required of your application. Take a moment to familiarize yourself with the unit's front panel controls and indicators.





## Power On



*The Series C controller's functional hierarchy is organized into three distinct user-programmable groupings: Security Level, Menu System, and Operating Mode.*

When power is first applied to the Series C, all segments of the LED displays will be momentarily illuminated while the instrument goes through a series of diagnostic checks to verify proper operation. A software version number will then appear in the lower display, followed by a configuration code (upper display) and the communications protocol which is supported (lower display).

**IMPORTANT:** On initial startup, there is a possibility that outputs may be activated. We recommend placing the unit in Standby mode until you have configured the controller according to your application requirements. To place the controller in Standby, follow this procedure:

- 1) Press and hold Mode/Enter  key until a menu label appears in upper display (approximately three seconds).
- 2) Press Raise  or Lower  key until **5454** appears in the lower display.
- 3) Press Mode/Enter  key. (The upper display will alternate between **5454** and process value.)





### Operations Overview

The user interface of the Series C allows you to use menus to set up the instrument, set the desired security level, change the setpoint, and conveniently change operating modes. Figure 9 on page 20 provides a functional representation of the user interface and the key presses necessary to perform the basic functions.

*Please provide the software version number, communications protocol, and the controller's full model number, when contacting us regarding your controller.*

## Security Levels







*The controller's initial security level, set at the factory, is Configuration **CONF**. When you have completed configuring the instrument, we recommend the security level be set to the most restrictive level suitable for your application.*

The security level feature allows you to limit access to the menus, setpoint, and operating mode selection according to the needs of your application. The security levels provided are Key Lockout, Setpoint, Setpoint plus Mode, User, Configuration, and Factory. To view or change security level from the Process Variable display, press and hold the Menu Access  key for approximately 10 seconds. (Ignore the menu label that will appear in the upper display after approximately three seconds.) The controller will display **AccL** (Access Level) and the current security level label, e.g., **USER**. Use the Raise  or Lower  keys to index through the security levels. Press the Mode/Enter  key once to select the new security level desired and return to the Process Value display.



## Security Levels

### Security Levels and Access Restrictions

 Key Lockout	Highest security level. No access to any controller functions. To escape, follow instructions above for changing security levels.
 Setpoint	No access to menus. Only allows setpoint value or output percentage (manual mode) to be changed.
 Setpoint plus Mode	No access to menus. Only allows setpoint value, output percentage (manual mode), or operating mode to be changed.
 User	All "Setpoint" level privileges as well as access to Operating Mode, Autotune, and Control menus.
 Configuration	All "User" level privileges as well as Input, Output, Display, and Supervisor menus
 Factory	All "Configuration" level privileges as well as access to Calibration menu.

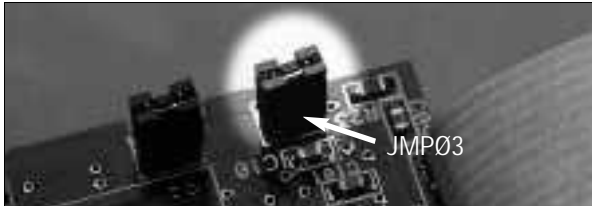



















**NOTE:** Removing this jumper on the microcontroller board disables the keypad, thus preventing any operator access.

## Operating Modes

*Remember to press the Mode/Enter key after making your selection.*

*If both outputs are set to OFF or ALr, the Series C will function as a non-controlling indicator. Control outputs will be disabled and the Operating Modes will not be displayed.*

The Series C's operating modes are: Manual, Standby, Normal, Autotune, Ramp/Soak Recipe, Run and Hold. To select a different operating mode, press the Mode/Enter  key for three seconds. The operating mode that the controller is currently in will be displayed. To index through the available operating modes, press the Raise  or Lower  keys. When the desired mode is displayed, press the Mode/Enter  key once to select the mode.

		Manual
		Standby
		Normal
		Autotune <i>(Only available when unit is placed in Standby mode and one output is PID.)</i>
		Start Ramp/Soak Recipe <i>(Only when programmed.)</i>
		Run <i>(Only available when recipe is active.)</i>
		Hold <i>(Only available when recipe is active.)</i>

**A description of the available operating modes is provided on the next page.**

## Operating Modes





*Manual operating mode overrides automatic control, allowing you to control the outputs using a fixed percentage of output power, regardless of the process variable or setpoint.*

*If current automatic control is PID, transfer to Manual mode is “bumpless.”*

<b>FOP</b>	Manual	Used to set control output percentage (Fixed Output Percentage) independent of Process Value. To set percentage, use the Menu Access  key to select <b>FPE</b> and the Raise or Lower keys to set the value. <b>PCE 1</b> is displayed if Output 1 is a control output. <b>PCE 2</b> is displayed if Output 2 is a control output.
<b>STBY</b>	Standby	Used to disable control outputs.
<b>NO</b>	Normal	Normal automatic control.
<b>RTUN</b>	Autotune	Used to initiate the autotuning sequence (from Standby only).
<b>R.S</b>	Ramp/Soak Recipe	Used to start ramp/soak recipe mode.
<b>R.S. R</b>	Run	Used to enable Run function
<b>R.S. H</b>	Hold	Used to enable Hold function

## Menu System Overview

*If a key press is not sensed within five minutes, the controller automatically exits the Menu System and reverts to the Process Value display.*

The Parameter Menu System is organized into ten basic menus: Input, Display, Output, Control, Alarm, Tune, Recipe, Supervisor, Calibration, and Option. To access the Menus, press and hold the Menu Access  key for approximately 3 seconds until a menu label appears in the upper display. There are additional menus presented when an option is selected under the Option menu; however, the options are non-functional unless the appropriate option board has been installed. Pressing the Menu Access  key indexes from menu to menu. Pressing the Mode/Enter  key indexes through the parameters in a particular menu. The Raise and Lower   keys are used to modify the visible menu parameter.

Each menu contains a logical group of parameters related to one another. Furthermore, the sequence of the menus has been carefully chosen to put the most important setup menus first.

# Menu System Overview

Figure 10. Series C Functional Diagram

To return to Process Value at any time, press and hold Menu Access  key for three seconds

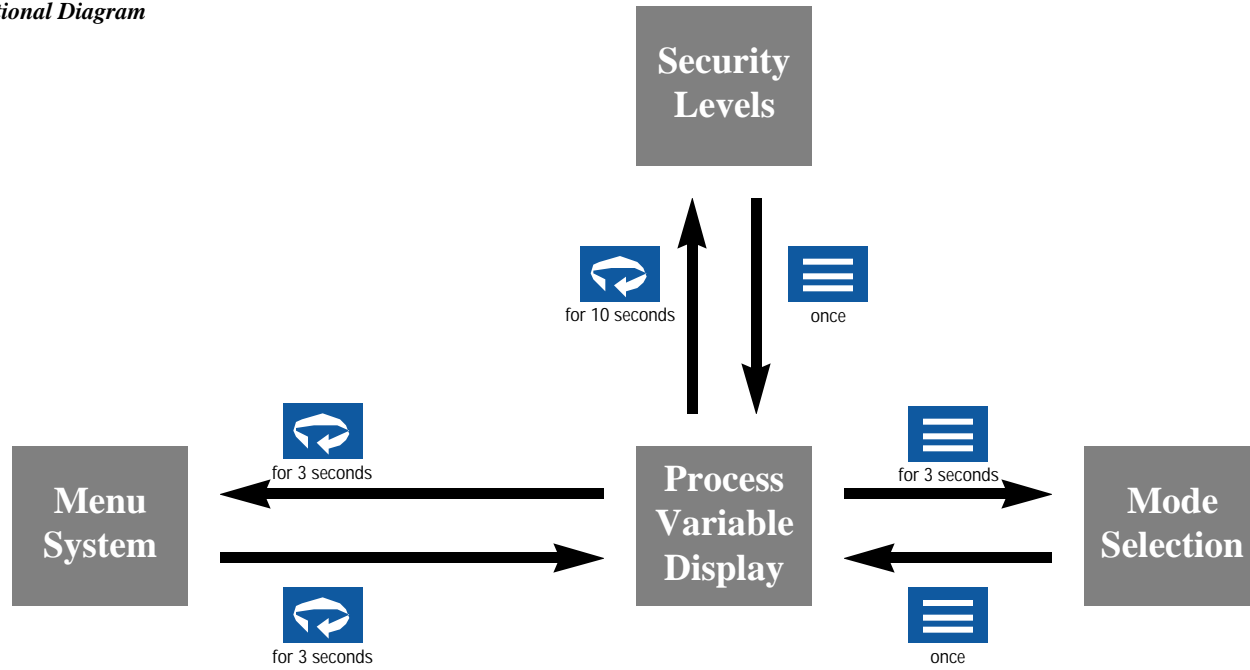

# Menu System Overview

Figure 11. Chart of Series 18C/25C Menu System and Security Levels



Menu Access Key



Mode/Enter Key

INP	DISP	OUTP	Ctrl	RLr	temp	r-S	SUPP	CBL	OPtr	SErL	dIn	rPS	ADuE			
TYPE	USCP	01.2Y	01.R2	db1	RLAR	0PnB	0rS	rOPt	dIS	ESD1	CALo	CRd	Idno	Func	SCLL	OUtU
51RS	dfLL	01.2Y	01.LL	db5.1	RLAR	HLdb	SSPr	ESD2	CALo	CRd	Idno	SSPS	SCLH	SCLL	SCLL	SCLL
SCLL	UtrE	01.HL		db2	RLdL	EErS	SSPr	LibrE		CRd	Idno	SSPS	SCLH	SCLL	SCLL	SCLL
SCLH	6LAn	02.2Y	02.R2	db5.2	RLdH	r2Yn	HLdb	HLrd		CRd	Idno	rSRH		dIS		
SPLL		02.2Y	02.LL	Pb1	RLSP	PRrE	EErS	LOrd								
SARL		02.HL		Pb2	R2AR			LdDP								
LFLL				dEr	R2AR	rL	(number)									
				OFFS	R2AL	rE	(number)									
				Int	R2AL	SL	(number)									
					R2HL	SE	(number)									
					R2SP	SE	(number)									

NOTE: Parameter labels displayed will vary, depending upon the controller's configuration.



Mode/Enter Key (three seconds)



Raise/Lower Key

fOP	rS	RLtrn	ndr	SLbY
-----	----	-------	-----	------

### Security Levels

**Lo20** (Key Lockout) = No Access

**SP** (Setpoint) = Setpoint Value or Output  
Percentage (Manual Mode)

**SPPL** (Setpoint plus Mode) = **SP** Plus [ ]

**USER** (User) = **SPPL** Plus [ ]

**CONF** (Configuration) = **USER** Plus [ ]















**FACT** (Factory) = **CONF** Plus [ ]

## Initial Setup Sequence

*If a key press is not sensed within five minutes, the Menu System is automatically exited and the controller reverts to the Operating Mode/Process Value display.*









*These setup instructions apply to PID-type control outputs.*

Many of the menu parameters you will need to set up the controller for your application are interdependent. We recommend following the steps below when configuring your Series C.

- 1) Place the unit in Standby Mode as follows. Press the Mode/Enter  key for three seconds. Press the Raise  or Lower  key to select Standby. Press the Mode key again and the upper display will alternate between **SETP** and the process value.
- 2) Input Type. Press and hold Menu Access  key for three seconds to access the menu system. The Input menu **INP** will be displayed. Then press Mode/Enter  key until **TYPE** appears. Use Raise  or Lower  key to select Input Type. *If Input Type is set to one of the linear input options, use the Mode/Enter  key to scroll to scaling limits, **L5CL** and **H5CL**, before proceeding. Use the Raise  or Lower  key to set low and high scaling limits.*
- 3) Output Type. Press the Menu Access  key to display **OUTP**. Use the Mode/Enter  key to index to the Output Type parameter. Using the Raise  or Lower  keys, select the correct Output Type for your application. Follow these steps (using the Mode/Enter and Raise or Lower keys) to set the Output Action, Cycle Time, and Limit parameters for PID outputs. Alarm or on/off output settings and displays will be different. Refer to Output menu description on page 31.

## Initial Setup Sequence

*IMPORTANT: Upon entering a new value, you MUST either press the Mode/Enter key, the Menu Access key, or index to a different parameter in order for the new value to register. The controller will NOT accept new values without a key press.*

- 4) If manually tuning the controller, set Control Menu parameters by pressing the Menu Access  key repeatedly until **Ctrl** is displayed. Then, use the Mode/Enter  key to index through the available selections and the Raise  or Lower  keys to select the appropriate setting. Otherwise, proceed to Step 6.
- 5) If autotuning the controller, press and hold the Menu Access  key for three seconds to access the menu system. Press the Menu Access key repeatedly until the Autotune Damping parameter **TUNE** is displayed. Make sure the Damping parameter is set properly (see page 37). Press and hold the Menu Access  key for three seconds to return to the Process Variable display and proceed to Step 4 on page 43.
- 6) Return to Process Variable Display. Press and hold the Menu Access  key for three seconds to return to PV display.
- 7) Adjust setpoint. Use the Raise  or Lower  key to enter the desired setpoint. Wait for process to stabilize before proceeding, e.g., in the case of a heating process, return to ambient temperature.
- 8) Security Level. Press and hold the Menu Access key for approximately 10 seconds until **RSLV** is displayed. Using the Raise or Lower keys, set the most restrictive level suited to your application. See page 16.

# Menus and Parameter Descriptions

## Menus and Parameters

<b>INP</b> Input	Used to select sensor-related parameters, such as input type, limits, and scaling.
<b>DISP</b> Display	Used to set or change decimal position and display units.
<b>OUTP</b> Output	Used to specify output usage, control methods, and alarms.
<b>CTRL</b> Control	Used to select parameters associated with the control methods.
<b>ALM</b> Alarm	Used to select alarm parameters . <i>Note: This menu is also functional for controllers <u>not</u> equipped with alarm hardware; however, alarm indication will be only visual via the A1 and A2 LEDs on the front panel.</i>
<b>TUNE</b> Tune	Used to set the autotune damping parameter.
<b>R-S</b> Recipe	Used to set ramp and soak parameters.
<b>SUP</b> Supervisor	Used to set fail-safe and supervisory parameters.
<b>CAL</b> Calibration	Used to recalibrate input.
<b>OPTN</b> Option	Used to select installed option.
<b>SEPL</b> Communications	(Option) Used to set serial communications parameters.
<b>DLN</b> Contact/Digital Input	(Option) Used to select switch input functions.
<b>RAS</b> Remote Analog Setpoint	(Option) Used to enter remote analog setpoint parameters.
<b>AOUT</b> Auxiliary Output	(Option) Used to set auxiliary output parameters.

## Input Menu

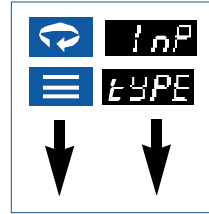

**NOTE: FOR A MORE DETAILED DESCRIPTION OF MENU PARAMETERS, REFER TO THE GLOSSARY WHICH BEGINS ON PAGE 61.**

The first parameter that needs to be set is Input Type. The remaining Input Menu parameters will change, depending upon whether a linear input type or a temperature input type is selected. Other menu parameters related to the sensor range may also change. After selecting your Input Type, refer to the corresponding section on page 29 for the remainder of the Input Menu parameters.

### Input Menu

Display Parameter

**TYPE** Input Type

Selection

- J** Type J thermocouple
- b** Type B thermocouple
- C** Type C thermocouple
- E** Type E thermocouple
- K** Type K thermocouple
- N** Type N thermocouple
- NIC** Type NIC thermocouple
- NNM** Type NNM thermocouple
- R** Type R thermocouple
- S** Type S thermocouple
- T** Type T thermocouple
- PL2** Platinel II thermocouple
- RTD** 100 ohm platinum RTD

## Input Menu

### Input Menu (continued)

Display	Parameter	Selection
<b>0000</b>	Input Type	<b>0000</b> 100 ohm compressed RTD
<b>0200</b>		<b>0200</b> 0-20 mA
<b>0400</b>		<b>0400</b> 4-20 mA
<b>0100</b>		<b>0100</b> 0-10 mV
<b>0500</b>		<b>0500</b> 0-50 mV
<b>0100</b>		<b>0100</b> 0-100 mV
<b>1000</b>		<b>1000</b> 10-50 mV
<b>0-1</b>		<b>0-1</b> 0-1 V
<b>0-5</b>		<b>0-5</b> 0-5 V
<b>0-10</b>		<b>0-10</b> 0-10 V
<b>1-5</b>		<b>1-5</b> 1-5 V

### Input Jumper Settings

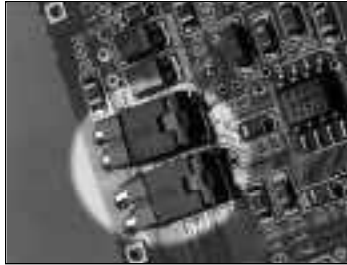

Input Type	JMP01	JMP02
Thermocouple	Out	Out
RTD	Out	Out
Voltage <100 mV	Out	Out
Voltage >100 mV	In	Out
Current Process	In	In

Note: When you ordered your controller, an input type was specified and the controller was set up accordingly and calibrated for that input type at the factory. If you decide to change input type from thermocouple to RTD or vice-versa, you will need to recalibrate the controller unless you ordered the "Calibrate All" option. (Refer to page 53 for information on recalibration.) If you are changing from a temperature input type to a linear input type, you MUST recalibrate and change the jumper settings as indicated in the above table.

## Input Menu

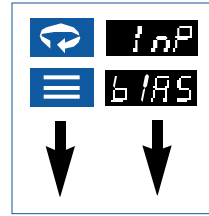

### Temperature Input Type

Display	Parameter	Selection
<b>0100</b>	Bias	-100 to 100
<b>5000</b>	Lower Setpoint Limit	Span of Sensor
<b>5000</b>	Upper Setpoint Limit	Span of Sensor
<b>1000</b>	Filtering	0.1-10.0 sec.

### Linear Input Type

Display	Parameter	Selection
<b>0100</b>	Bias	-100 to 100
<b>5000</b>	Low Scale	-1999 to 9999
<b>5000</b>	High Scale	-1999 to 9999
<b>5000</b>	Lower Setpoint Limit	Span of Sensor
<b>5000</b>	Upper Setpoint Limit	Span of Sensor
<b>1000</b>	Filtering	0.1-10.0 sec.

## Display Menu

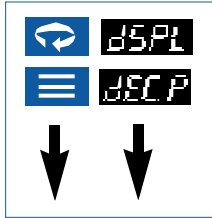

Display Parameter	Selection
<b>DEC P</b> Decimal Position	0-3 Linear Inputs 0-1 TC/RTD
<b>FILT</b> Filter	0.1-10.0 sec
<b>UNITS</b> Units*	<b>F</b> Fahrenheit <b>C</b> Celsius <b>K</b> Kelvin
<b>BLANK</b> Blanking	<b>OFF</b> , 0-9999 sec

\*NOTE: Does not appear for linear inputs.

## Output Menu

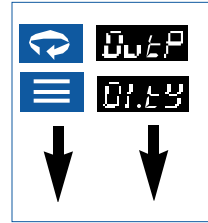

The first parameter that needs to be set in the Output Menu is the Output Type. There are three possible Output Type configurations: PID, On/Off, or Off. (If you are not sure which Output Type is best for your particular application, refer to the Glossary for an explanation of Output Types.) The remaining menu parameters in the Output Menu will change, depending on the Output Type selected. The Control Menu will also change, depending on the Output Type selected. If you ordered two outputs, you can select two different Output Types. After setting your Output Type, refer to the corresponding sections below for the remaining Output Menu parameters. For simplification purposes, the following sections assume the same Output Type for both outputs. If you selected different Output Types, refer to both of those sections.

### Output Type

Display Parameter	Selection
<b>OUT 1</b> Output 1 Type	<b>PID</b> <b>on/off</b> <b>OFF</b>
<b>OUT 2</b> Output 2 Type	<b>PID</b> <b>on/off</b> <b>OFF</b>



## Output Menu

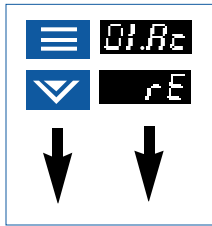

### PID Output Type

<b>01.A2</b>	Output 1 Action	<b>rE</b> (Reverse-acting) <b>dir</b> (Direct-acting)
<b>01.C3</b>	Output 1 Cycle Time*	0.2; 1 to 120 seconds
<b>01.L4</b>	Output 1 Low Limit	1-100%
<b>01.H4</b>	Output 1 High Limit	1-100%
<b>02.A2</b>	Output 2 Action	<b>rE</b> (Reverse-acting) <b>dir</b> (Direct-acting)
<b>02.C3</b>	Output 2 Cycle Time*	0.2; 1 to 120 seconds
<b>02.L4</b>	Output 2 Low Limit	1-100%
<b>02.H4</b>	Output 2 High Limit	1-100%

### \*Recommended Cycle Time Settings

Output Type	Recommended Setting (seconds)
B (5A/3A)	15 to 120
E (0-20 mA)	0.2
F (4-20 mA)	MUST be set to 0.2
G (4-20 mA)	MUST be set 0.2
S (pulsed 20 Vdc)	0.2
T (S.S. relay)	15 to 120**
Y (5A/3A) N.C.	15 to 120 (Output 2 only)

\*\*\*T" outputs directly driving non-inductive loads (small heaters) can have cycle times as low as 0.2 seconds.

## Control Menu

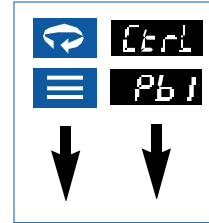

### PID Output Type

As with the Output Menu, the Control Menu will change, depending upon the Output Type selected. *Note: These parameters are automatically set during the autotune procedure. We do not recommend altering the value of these control parameters unless your process requires manual tuning.*

Display	Parameter	Selection
<b>PB1</b>	Proportional Band 1	1...to span of sensor
<b>PB2</b>	Proportional Band 2	1...to span of sensor
<b>DER</b>	Derivative Action (Rate)	0 to 2400 seconds
<b>OFFS</b>	Manual Reset	OFF, -100% to 100%

*NOTE: The Integral Action (Auto Reset) parameter appears only if OFF is selected in the Manual Reset parameter.*

<b>INT</b>	Integral Action (Auto Reset)	0 to 9600 seconds
------------	------------------------------	-------------------

*Setting Derivative (Rate) or Integral (Reset) to **0** disables that aspect of PID control.*

*If BOTH outputs are set to direct-acting or BOTH outputs are set to reverse-acting, then only one proportional band selection will be displayed.*

## Output Menu

### On/Off Output Type

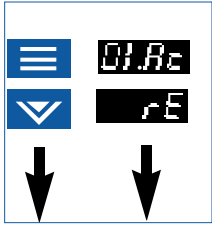

Display	Parameter	Selection
	Output 1 Action	(Reverse-acting) (Direct-acting)
	Output 2 Action	(Reverse-acting) (Direct-acting)

## Control Menu

### On/Off Output Type

If both outputs are set to in the Output Type Menu, the controller will function as a non-controlling indicator. Control outputs will be disabled and the Operating Modes will not be displayed.

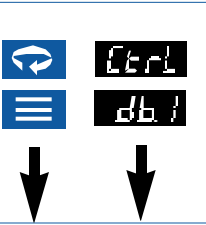

Display	Parameter	Selection
	Deadband 1	Negative span of sensor to positive span of sensor
	Hysteresis Output 1	1...to span of sensor
	Deadband 2	Negative span of sensor to positive span of sensor
	Hysteresis Output 2	1...to span of sensor

## Notes On Alarms

Four types of alarms are available: Process, Deviation, Inverse Band, and Normal Band. All alarms may be configured to be inhibited on power-up for a configurable time duration.

**Process Alarm:** Activates at preset value, independent of setpoint. "High" process alarm activates at and above alarm setting. "Low" process alarm activates at and below alarm setting.

**Deviation Alarm:** Activates at a preset deviation value from setpoint. "High" or "Low" deviation alarm activates above or below setpoint according to the preset deviation value.

**Inverse Band Alarm:** Activates when the process is within a specified band centered around the setpoint.

**Normal Band Alarm:** Activates when the process exceeds a specified band centered around the setpoint.

### Latching Alarms

The Series C's alarms may also be configured as latching alarms by selecting in the Alarm Action parameter selection.

*Deviation, Inverse Band, and Normal Band Alarms track with setpoint.*

*When a latching alarm has been activated and the alarm condition has been removed, the Mode/Enter key must be pressed to unlatch the alarm.*

## Alarm Menu

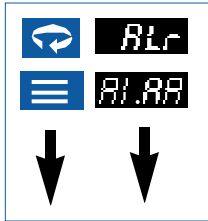

*Note: The Control Menu does not apply to an Alarm Output Type; therefore, the Control Menu does not appear.*

### Alarm Type

Display	Parameter
	Alarm Action
	Alarm Operation
	Alarm Delay
	Alarm Inhibit
	Alarm Setpoint
	Alarm Action
	Alarm Operation
	Alarm Delay
	Alarm Inhibit
	Alarm Setpoint

Selection
0-9999 sec
0-9999 sec
Span of Sensor
0-9999 sec
0-9999 sec
Span of Sensor

## Autotune Damping Menu

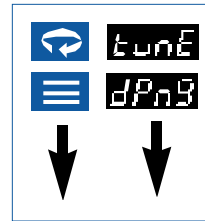

Display	Parameter
	Damping

Selection

Note: The damping parameter specifies how aggressively the controller performs its autotuning. The "Normal" setting is a compromise between the fast recovery and overshoot. The "Low" setting provides faster recovery, but with the possibility of overshoot; the "High" setting a slower recovery, but with minimum or no overshoot.

## Recipe (Ramp/Soak) Menu

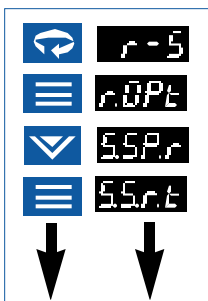

### Single Setpoint Ramp Time

This selection will cause the controller to 'ramp' the process from the starting point (current process value) to the setpoint in the time specified. This ramp will take place at startup when selected from the Ramp/Soak menu. The setpoint must be at least  $\pm 0.2\%$  of sensor span for the ramp to be employed.

### Multi-Step Ramp

This selection will enable the programming of a recipe (make all ramp/soak recipe variables visible). Recipes can be resumed on startup if interrupted by a power failure or initiated, held, and terminated from the front panel via the Mode Menu or with the logic input option (initiate and held/resumed only).

### Holdback Band

Specifies the maximum number of degrees above or below setpoint that the process can be for the segment timer to keep going. The timer will hold while the process settles back into the band and then continue. If this feature is not desired, this parameter should be set to **OFF** which will disable it.

### Termination State

This parameter determines what the control will do at the completion of a recipe. Last Setpoint refers to the last temperature specified in the ramp/soak recipe. Default Setpoint refers to the standard setpoint which was in effect prior to recipe initiation.

### Recycle Number

Specifies the number of times after the first time that the recipe is run before the program terminates.

## Recipe (Ramp/Soak) Menu

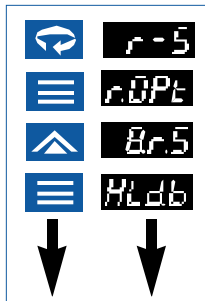

*If a ramp/soak error condition occurs, the upper display will toggle between **r-5** and the numeric error code for three seconds before the recipe terminates. Possible error codes are:  
02 = Recipe Empty (i.e. no non-zero ramp times)  
05 = Insufficient Setpoint-Process Value Deviation*

### Power Fail Resume

Setting this parameter to On will cause the control to resume a recipe which was active when a power failure occurred. The recipe will resume at the start of the last active ramp or soak segment.

### Ramp/Soak Events (1-8) (If alarms are configured as ramp/soak events.)

Ramp/Soak events occur at the beginning of their designated segment. All events are terminated once the recipe has been completed or terminated.

Display	Parameter	Selection
<b>r.0Pt</b>	Recipe Option	<b>SSPr</b> Single-Setpoint Ramp <b>8r.5</b> Multi-Step Ramp <b>OFF</b> Disabled
<b>SSrT</b>	Single-Setpoint Ramp Time*	1-9999 mins.
<b>HLdb</b>	Holdback Band	Off-100
<b>SSrS</b>	Termination State	<b>LRSt</b> Last Setpoint <b>DRPt</b> Default Setpoint <b>SSbY</b> Recipe to Standby

\*NOTE: Only available when single-setpoint ramp is selected.

## Recipe (Ramp/ Soak) Menu

For Ramp Events and Soak Events to be employed, Alarm 1 or Alarm 2 must be set for event usage **cont** in the Alarm Menu.

*NOTE: The following seven parameters are only available when multi-step ramp is selected.*

Display	Parameter	Selection
<b>rcy</b>	Recycle Number (Recipe Executions)	0-99, <b>cont</b>
<b>prf</b>	Power Fail Resume	<b>off</b> Off <b>on</b> On
<b>rt</b>	Ramp Times 1-8	0-9999 mins.
<b>re</b>	Ramp Events 1-8	<b>Al.on</b> Alarm 1 On <b>Al.off</b> Alarm 1 Off <b>Al2.on</b> Alarm 2 On <b>Al2.off</b> Alarm 2 Off <b>dis</b> Disabled
<b>sl</b>	Soak Levels 1-8	Display Units, FS
<b>st</b>	Soak Times 1-8	0-9999 mins.
<b>se</b>	Soak Events 1-8	<b>Al.on</b> Alarm 1 On <b>Al.off</b> Alarm 1 Off <b>Al2.on</b> Alarm 2 On <b>Al2.off</b> Alarm 2 Off <b>dis</b> Disabled

## Supervisor Menu

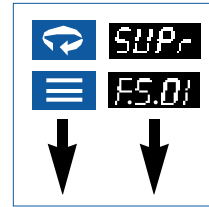

*The Failsafe State is only enforced when a problem is detected with the process input. It is not reliably enforceable in instances of internal circuitry failure such as EEPROM problems.*

*Output % High Limits are ignored when the unit enters a Failsafe State.*

Display	Parameter	Selection
<b>FS.01</b>	Output 1 Failsafe State	0 to 100% of output
<b>FS.02</b>	Output 2 Failsafe State	0 to 100% of output
<b>Lbrt</b>	Loop Break Time	Off, 4-9600 sec
<b>Hlrd</b>	Highest Reading	n/a
<b>Llrd</b>	Lowest Reading	n/a
<b>LdDP</b>	Load Default Parameters	<b>YES</b> <b>no</b>

*Choosing "Yes" to Load Default Parameters resets all menu parameters to factory settings.*

## Calibration Menu

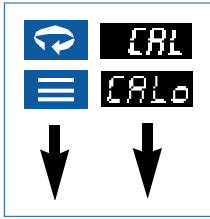

**CALo** Toggles with the temperature value that should be input to perform the low calibration operation.

The low calibration operation is triggered by pressing the up arrow key.

**CALh** Toggles with the temperature value that should be input to perform the high calibration operation.

The high calibration operation is triggered by pressing the up arrow key.

## Options Menu

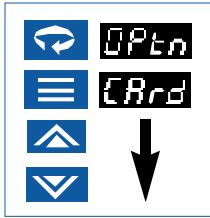

Display Parameter

**CRd** Installed Card

Selection

**none**

**SER** Serial Communications

**AIN** Switch Input (Digital Input)

**RA5** Remote Analog Setpoint

**AO5** Auxiliary Output

## Autotuning

*In order for the controller to autotune properly, the setpoint value must be at least 1% of span above or below the initial process value. Make sure that the Setpoint Target Time parameter is set to OFF.*

*Tuning accuracy increases as the spread between ambient and setpoint value increases.*

*Tuning should be performed with system in equilibrium (no latent energy remaining).*

To place the controller in Autotune mode:

- 1) Configure the controller by following the directions for Initial Setup Sequence through Step 3 on page 22. Set damping parameter. (See page 26.)
- 2) If the controller is not already in Standby mode, place it in Standby now as follows. Press and hold the Mode/Enter **≡** key for three seconds. Display will indicate your current operating mode. Press the Raise **▲** key or Lower **▼** key to select Standby. Press Mode key again and the display will alternate between **STBY** and the process value. This will deactivate all outputs.
- 3) If Setpoint Value has not been entered, adjust setpoint now by using the Raise or Lower key to set the desired setpoint.
- 4) Wait for process to stabilize before proceeding, e.g., in the case of a heating and cooling process, return to ambient temperature.
- 5) Initiate Autotuning. Press and hold the Mode/Enter key again for three seconds, then press the Raise or Lower key repeatedly until **RTUN** appears. Finally, press the Mode/Enter key again. The display will alternately indicate **TUNE** and process value as the controller “learns” the proper proportional band, derivative, and integral values for the process. If unacceptable overshoot occurs on restart, shut down the process and increase the damping setting. If sluggish response is observed, shut down the process and decrease the damping setting.

## Autotuning

If a tune error condition occurs, the upper display will toggle between **TUNE** and a numeric error code for three seconds before the tune process terminates. The controller will then automatically go into Standby mode when a tuning error occurs. Possible error codes are:

02 = No PID Device Configured

03 = Incorrect Output Action

05 = Insufficient Setpoint-Process Value Deviation

08 = Invalid Tune Results

09 = Tune Timeout

### Autotuning Procedure Diagram

Note: Keep in mind that the setpoint value must be at least 1% of span above or below the initial setpoint, and that the process value must be stable prior to initiating the tune.

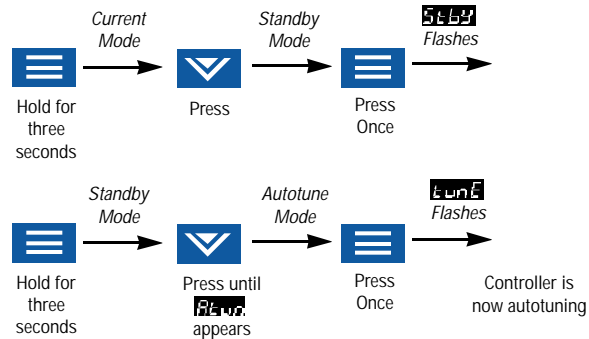

## Manual Tuning

*While some processes other than heat or cool applications may respond successfully to autotuning procedures, the controller may need to be manually tuned for non-temperature processes.*

### Manual Tuning Procedure (Zeigler-Nichols PID Method)

This tuning method may be used for non-temperature control processes or if the spread between ambient temperature and process operating temperature is small. For best results, the use of a recording device is required when tuning with this method.

- 1) For temperature control processes, disable any cooling device used.
- 2) With the power off and the controller NOT in the Key Lockout security level, apply power and immediately put the controller in Standby mode by pressing the Mode/Enter **≡** key for three seconds, the Raise **▲** key until **STBY** appears and press the Mode/Enter **≡** key again.
- 3) If you have a direct-acting output, it must be disabled before proceeding further **OUTY** = **OFF**.
- 4) Under the Control menu, make sure that the derivative term **DER**, the offset term **OFFS**, and the integral term **INT** are all set to zero, and the proportional band **PB1** or **PB2** is set to the maximum setting.
- 5) Adjust setpoint to the desired value with the Raise/Lower keys.
- 6) Press the Mode/Enter **≡** key for four seconds, the Raise **▲** key twice **RDY**, and the Mode/Enter key again to return the controller to normal operation.

# Manual Tuning

- 7) While monitoring the recording device, decrease the proportional band value by repeatedly halving the value until a small, sustained temperature oscillation is observed. Measure the period of one cycle of oscillation ("T" on the diagram below).

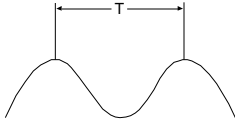

- 8) Divide the period of oscillation (T) by eight. The resulting number is the correct Derivative **Der** time in seconds. Multiply this number by four. This is the correct Integral time **Int** in seconds.
- 9) Multiply the bandwidth value obtained in Step 7 by 1.66 and enter this as the new proportional band value.

# Error Codes

*If an error code cannot be cleared by using the actions provided, contact factory.*

Display	Problem	Actions
<b>ErrH</b>	Open Sensor	Check sensor, wiring, and Input.
<b>ErrL</b>	Reversed Sensor	Check the type selection in the Input menu, and check sensor polarity.
<b>LPbr</b>	Loop Break	Correct problem and reset controller.
<b>0100</b>	Checksum Error	Press any key to perform a soft reset and reinitialize controller.
<b>0101</b>	RAM Error	
<b>0202</b>	Defaults Loaded	
<b>0303</b>	EEPROM Write Failure	
<b>3865</b>	Power Fail Resume Feature Disabled	No further resume actions available.
<b>75</b> Plus other 2-Digit Code	Unexpected or Invalid Interrupt	Reset controllers



## Technical Specifications

Operating Limits	
Ambient Temperature	32°F to 140°F (0°C to 60°C)
Relative Humidity Tolerance	90%, Non-Condensing
Power	100 to 250 V 50/60 Hz (Single-Phase) 100 to 250 Vdc 24 Vac/dc
Power Consumption	Less than 6 VA
Performance	
Accuracy	±0.20% of Full Scale (±0.10% Typical), ±1 Digit
Setpoint Resolution	1 Count / 0.1 Count
Repeatability	±1 Count
Temperature Stability	5 µV /°C (Maximum)
TC Cold-End Tracking	0.05°C /°C Ambient
Noise Rejection	>100 dB Common Mode, >70 dB Series Mode
Process Sampling	10 Hz (100 ms)
Control Characteristics	
Setpoint Limits	Automatically Adjust to Selected TC/RTD
Alarms	Adjustable for High/Low; Selectable Process, Deviation, or Band Alarms
Proportional Band	1 to Span of Sensor

## Technical Specifications

Integral	0 to 9600 Seconds
Derivative	0 to 2400 Seconds
Cycle Time	200 ms; 1 to 120 sec
Control Hysteresis	1 to Span of Sensor
Autotune	Operator Initiated from Front Panel
Manual Control	Operator Initiated from Front Panel
Mechanical Characteristics	
Display	Dual, 4-digit 0.36" (9.2 mm) LED display Process Value: Orange Setpoint Value/Menu: Green
Numeric Range	-1999 to 9999
Front-Panel Cutout	1.771" x 1.771" (45 mm x 45 mm)
Depth Behind Panel	3.937" (100 mm)
Front Panel Rating	NEMA 4X
Operating Temperature	32 to 140° F (0 to 60° C)
Humidity Conditions	90% R.H. max., non-condensing
Parameter Retention	Solid-state, non-volatile memory
Connections	Input and output via barrier strip with locking terminals
Contacts	Twin bifurcated

## Technical Specifications

### Input Type

Thermocouple	B, C, E, J, K, N, NIC, NNM, R, S, T, Platinel II Maximum lead resistance 100 ohms for rated accuracy
RTD	Platinum 2- and 3-wire, 100 ohms at 0° C, DIN curve standard (0.00385) 1000 ohms available
Linear	0-50 mV/10-50 mV, 0-5 V/1-5 V 0-20 mA/4-20 mA, 0-100 mV, 0-10 V

### Output Device

B	5 A (120/240 Vac) relay, normally open, used for switching resistive loads. If relays or solenoids are to be driven, select the "T" output. If a "B" output is selected, order snubber network 235Z005U01.
E	0-20 mA
F	4-20 mA, full output to load with 500 ohm impedance max.
G	High impedance 'F' (700 ohms max.)
S	20 Vdc pulsed output for solid-state relays.

## Technical Specifications

T

1 A @ 120/240 Vac , solid-state relay, zero  
voltage-switched and optically isolated from  
drive signal. Only resistive loads to 1A may  
be controlled directly. Larger loads may be  
controlled using an external contactor.

Y

5 A (120/240 Vac) relay, but normally  
closed (output 2 only).

### Alarm Type

See ordering code on page 52.

## Ordering Codes

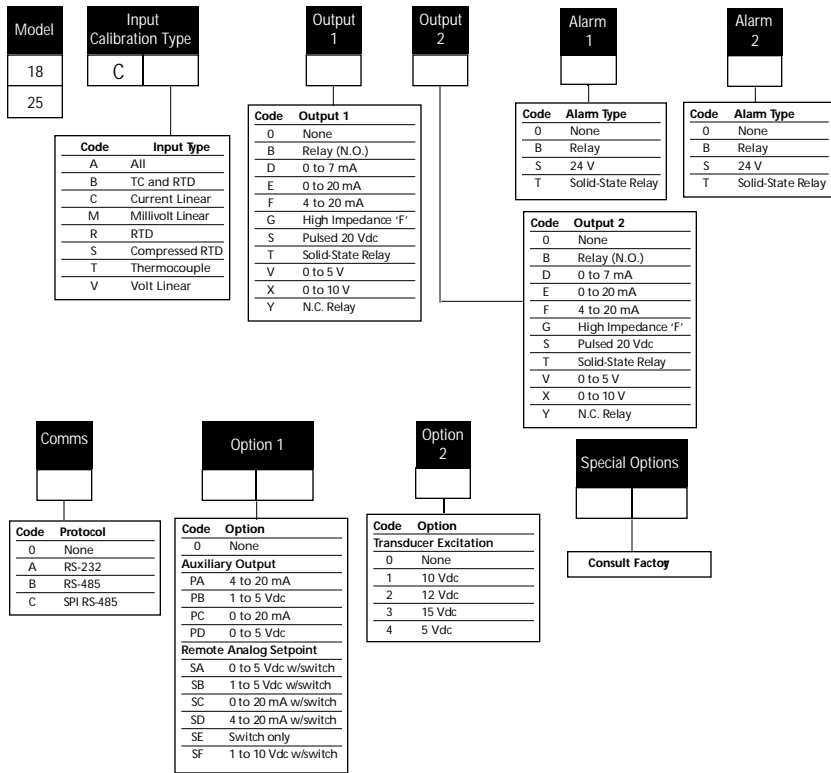

## Recalibration Procedures

*The Series C controller is precalibrated at the factory. Under normal circumstances, the factory calibration should be valid for the life of the instrument. If recalibration should be required, allow the controller to warm up for 15 minutes and follow these steps carefully.*





- 1) Remove power from the controller and disconnect all output devices. Disconnect input. Attach an appropriate calibrator to the input terminals.
- 2) Apply power to the calibrator, making sure that the displayed value is not outside the range of the controller. Then, apply power to the controller.
- 3) Index to the Calibration Low menu item in the Calibration Menu.  
(You must have Security Level set to "Factory" to access this menu.)
- 4) Dial Calibrator to prompted value on the controller's display. See chart below for RTD resistance vs. temperature values.
- 5) Allow the controller to settle for at least one minute.
- 6) Press Raise  $\blacktriangle$  Key.
- 7) Repeat Steps 4, 5, and 6 for the Calibration High setting.
- 8) Press the Menu Access key for three seconds to return to the Process Value display.





















Calibration Values				
	Low Calibration		High Calibration	
	Resistance Setting $\Omega$	Temperature Equivalent $^{\circ}\text{F} (^{\circ}\text{C})$	Resistance Setting $\Omega$	Temperature Equivalent $^{\circ}\text{F} (^{\circ}\text{C})$
RTD	100	32 $^{\circ}$ (0 $^{\circ}$ )	365.94	1414 $^{\circ}$ (768 $^{\circ}$ )
RTD (Decimal)	100	32 $^{\circ}$ (0 $^{\circ}$ )	221.95	622.4 (328 $^{\circ}$ )

## Quick-Helps

1. To return the unit to last operating mode (Normal, Standby, FOP, or Tune):







	Action	Display
From Menu System:	Press and hold  for 3 sec.	PV + SV + Mode
From Security Level Menu:	Press 	PV+ SV + Mode

2. To enter Standby operating mode:





	Action	Display
From Normal operating mode:	Press and hold  for 3 sec.	
	Press 	
	Press 	 + PV + SV
From FOP (Manual) operating mode:	Press and hold  for 3 sec.	
	Press 	
	Press 	 + PV + SV
From Menu System:	Press and hold  for 3 sec.	
	Press and hold  for 3 sec.	
	Press 	
	Press 	 + PV + SV

## Quick-Helps







2. To enter Standby operating mode: (cont.)

From Security Level Menu:	Press 	PV + SV
	Press and hold  for 3 sec.	
	Press 	
	Press 	 + PV + SV

3. To escape from Standby operating mode:





Action	Display
Press and hold  for 3 sec.	
Press 	
Press 	PV + SV

4. To initiate Autotuning:





Action	Display
Enter Standby operating mode (See Quick-Help #2)	
Press 	
Press 	
Press 	 + PV + SV

## Quick-Helps

5. To abort Autotuning and return to normal operation:

Action  
Press and hold  for 3 sec.   
Press  



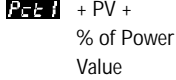



6. To enter FOP (Manual) operating mode:

Press   
Action  
Press and hold  for 3 sec.   
Press  

Press   to set new % of Power Value

Press  to set % of Power for Output 2 if desired. 

7. To escape from FOP (Manual) operating mode:

Action  
Press and hold  for 3 sec.   
Press    
Press  

## Warranty/ Repairs

### Two-Year Limited Warranty

THIS EQUIPMENT IS WARRANTED TO BE FREE FROM DEFECTS OF MATERIAL AND WORKMANSHIP. IT IS SOLD SUBJECT TO OUR MUTUAL AGREEMENT THAT THE LIABILITY OF ATHENA CONTROLS, INCORPORATED IS TO REPLACE OR REPAIR THIS EQUIPMENT AT ITS FACTORY, PROVIDED THAT IT IS RETURNED WITH TRANSPORTATION PREPAID WITHIN TWO (2) YEARS OF ITS PURCHASE.

THE PURCHASER AGREES THAT ATHENA CONTROLS, INCORPORATED ASSUMES NO LIABILITY UNDER ANY CIRCUMSTANCES FOR CONSEQUENTIAL DAMAGES RESULTING FROM ITS USE OR FROM IMPROPER HANDLING OR PACKAGING OF SHIPMENTS RETURNED TO THE FACTORY. COMPONENTS WHICH WEAR OR WHICH ARE DAMAGED BY MISUSE ARE NOT WARRANTED. THESE INCLUDE CONTACT POINTS, FUSES, ELECTROMECHANICAL RELAYS, AND TRIACS. UNITS WHICH HAVE BEEN MODIFIED BY A CUSTOMER IN ANY WAY ARE NOT WARRANTED.

Other than those expressly stated herein, THERE ARE NO OTHER WARRANTIES OF ANY KIND, EXPRESS OR IMPLIED, AND SPECIFICALLY EXCLUDED BUT NOT BY WAY OF LIMITATION, ARE THE IMPLIED WARRANTIES OF FITNESS FOR A PARTICULAR PURPOSE AND MERCHANTABILITY.

IT IS UNDERSTOOD AND AGREED THE SELLER'S LIABILITY WHETHER IN CONTRACT, IN TORT, UNDER ANY WARRANTY,

## Warranty/ Repairs

IN NEGLIGENCE OR OTHERWISE SHALL NOT EXCEED THE RETURN OF THE AMOUNT OF THE PURCHASE PRICE PAID BY THE PURCHASER AND UNDER NO CIRCUMSTANCES SHALL SELLER BE LIABLE FOR SPECIAL, INDIRECT, INCIDENTAL OR CONSEQUENTIAL DAMAGES. THE PRICE STATED FOR THE EQUIPMENT IS A CONSIDERATION IN LIMITING SELLER'S LIABILITY. NO ACTION, REGARDLESS OF FORM, ARISING OUT OF THE TRANSACTIONS OF THIS AGREEMENT MAY BE BROUGHT BY PURCHASER MORE THAN ONE YEAR AFTER THE CAUSE OF ACTION HAS ACCRUED.

SELLER'S MAXIMUM LIABILITY SHALL NOT EXCEED AND BUYER'S REMEDY IS LIMITED TO EITHER (i) REPAIR OR REPLACEMENT OF THE DEFECTIVE PART OR PRODUCT, OR AT SELLER'S OPTION (ii) RETURN OF THE PRODUCT AND REFUND OF THE PURCHASE PRICE, AND SUCH REMEDY SHALL BE BUYER'S ENTIRE AND EXCLUSIVE REMEDY. THE SPECIFICATIONS PUT FORTH IN THIS MANUAL ARE SUBJECT TO CHANGE WITHOUT NOTICE.

### *Unit Repairs*

It is recommended that units requiring service be returned to an authorized service center. Before a controller is returned for service, please consult the service center nearest you. In many cases, the problem can be cleared up over the telephone.

## Warranty/ Repairs

When the unit needs to be returned, the service center will ask for a detailed explanation of problems encountered and a Purchase Order to cover any charge. This information should also be put in the box with the unit. This should expedite return of the unit to you.

This document is based on information available at the time of its publication. While efforts have been made to render accuracy to its content, the information contained herein does not purport to cover all details or variations in hardware, nor to provide for every possible contingency in connection with the installation and maintenance. Features may be described herein which are not present in all hardware. Athena Controls assumes no obligation of notice to holders of this document with respect to changes subsequently made.

Proprietary information of Athena Controls, Inc. is furnished for customer use only. No other use is authorized without the written permission of Athena Controls, Inc.

# IEC Requirements



USE OF THIS EQUIPMENT IN A MANNER NOT SPECIFIED BY THE MANUFACTURER MAY IMPAIR PROTECTION PROVIDED BY THE EQUIPMENT!

The maximum supply current is line voltage dependent:

230 mA for a 24 Vac/dc input fuse rating=700 mA  
60 mA for an 85-250 Vac input fuse rating=100 mA

### Output Specifications

Output Type	Max current	Voltage	Leakage
B	5 A	250 Vac	1000 M ohms
T	1 A	250 Vpk	1 mA
S	20 mA	5 V	NA

### CLEANING INSTRUCTIONS

1. Remove power from the unit prior to any cleaning operation.
2. Use a cotton cloth to gently and sparingly apply isopropyl alcohol only. Do not use cleaners or other solvents as they may damage the unit.
3. Allow the unit to dry completely prior to reapplying power.

# Glossary

**Alarm Delay** - the time delay between the detection of the alarm condition and the initiation and indication of the output action.

**Alarm Inhibit** - prevents low setpoint alarm activation during cold startup applications.

**Bias** - allows the operator to compensate for any difference between sensor temperature and the point to be measured. The process display and setpoint will be offset by the value entered in the Bias parameter in the input menu. Ex: Desired temperature is 150 degrees. Sensor is adjacent to heater and reads 50 degrees higher than the actual process temperature. Enter bias of -50. Enter setpoint of 150. Process will display 150 even though sensor will be measuring 200 degrees.

**Blanking** - controls the time the setpoint value display remains on. After the set time, the setpoint value display turns off. Pressing any button causes the setpoint value display to reappear for the selected time interval.

**Cycle Time** - The period of time in which the controller's output completes an on-off cycle (Proportional Output Type only).

Example: Output type = Mechanical relay  
Cycle time = 10 seconds  
Output power = 50%  
Controller output = 5 seconds closed,  
5 seconds open

**Deadband** - In On/Off temperature control, it is the band above or below the setpoint where there is no output action. It has the effect of moving the apparent setpoint.

## Glossary

[Derivative](#) (rate) - Adjusts the controller gain quickly in response to load changes.

[Failsafe State](#) - designates the percentage of power output that the controller defaults to after it detects a loop break condition and after the loop break time has elapsed.

[Filter](#) (in Display menu) - changes the filtering speed for the process value display only. It does not affect control. This parameter is mainly used to slow down the flickering of the display when the decimal position chosen is greater than zero.

[Filtering](#) (in Input menu) - sets the time period over which the process value is averaged.

[Highest Reading](#) - records the highest process value read by the controller. It may be reset to zero by using the Raise or Lower arrow keys.

[Hysteresis](#) - In On/Off temperature control, hysteresis represents the band where the output changes state from deactivated to activated. It prevents chattering around the setpoint and prevents rapid output cycling.

[Integral](#) (automatic reset) - slowly adjusts the position of the Proportional Band (range of power output) to eliminate offset error.

[Loop Break](#) - a condition where the input is not changing or responding properly to the output action. This could be caused by a thermocouple or input failure, or a heater or load failure.

[Loop Break Time](#) - the time interval from when the controller detects a loop break condition and the initiation of the failsafe state.

[Lowest Reading](#) - records the lowest process value read by the controller. May be reset to zero by using the Raise or Lower arrow keys.

## Glossary

[Lower Setpoint Limit](#) - prohibits users from adjusting the setpoint lower than the selected value.

[Manual Reset](#) - an adjustment that moves the Proportional Band up or down by a fixed percentage so that more or less power is applied at setpoint. It is used to eliminate offset error.

[On/Off Output Type](#) - In a heating application, the controller applies 100% output power if the process temperature is below the setpoint and 0% at the setpoint. For a cooling application, the controller applies 100% output power if the process temperature is above the setpoint and 0% output power at the setpoint. There are only two output states: fully on and fully off.

*Applications for On/Off Control:*

1. When temperature oscillation is acceptable.
2. When constant cycling of mechanical devices is prohibited (Compressors, Blowers, etc.)
3. Under-powered processes

[Output Low Limit %](#) - Prohibits the controller's output from going below the specified percentage.

[Output High Limit %](#) - Prohibits the controller's output from going above the specified percentage.

[PID Output Type](#) (Proportional - Integral - Derivative) - The controller modulates output power by adjusting the output power percentage within a proportional band. Power is proportionally reduced as the process temperature gets closer to the setpoint temperature. PID control helps reduce overshoot on start-up, enhances stability, and compensates for process lag. The PID parameters are automatically



calculated for a particular application during the autotune procedure.

### *Applications for PID Control:*

1. Where process temperature lags exist
2. When load changes are present
3. When overshoot is prohibited
4. When very accurate control is required

**Proportional Band** - the band (expressed in degrees of temperature) in which the controller modulates its power percentage.

**Temperature Lag** - The product of thermal resistance and thermal capacity. Also defined as delay of the transmission of heat from the controlled element to the sensor caused by thermal mass of the process material and/or process container, or the distance between the control element and the sensor.

**Upper Setpoint Limit** - prohibits users from adjusting the setpoint higher than the selected value.

## Quick Setup Instructions - Series 18C/25C Temperature Controller



Experienced users, already familiar with the Series 18C/25C, and using the controller with PID outputs, may follow these condensed instructions to autotune the controller and get started quickly once the instrument is properly mounted and wired, and the Security Level is set to **Level 4**. Once setup is complete, we recommend changing the Security Level back to the most restrictive level suitable for your application.

These quick setup instructions are not meant as a substitute for reading the full instruction manual supplied with the controller. Please be sure to read through the manual for specific details of operation and, most importantly, for safety precautions. If you have any questions, or experience problems with setting up your controller, consult the full instruction manual first and, if you still need assistance, contact your Athena representative or call 1-800-782-6776.



Menu Access

















Raise



Lower



Mode/Enter

1. Apply power. After self-check display stops, place controller in Standby mode by pressing and holding the Mode/Enter  key for 3 seconds, the  or  key until **SEt** appears, and then the  key again. **SEt** will flash, alternating with the Process Value.
2. Press and hold the Menu Access  key for 3 seconds until **17P** is displayed. Press  key once until **12PF** appears, then use  or  keys to select sensor input type.
3. Press  to display **0.00**. Then press  once to display **0.00**. Use  or  to select **0.00**.
4. Press the  key until Output 1 Action **017P** is displayed. Select the desired output action using the  or  keys. (Reverse = Heating)

- Press **≡** again to display the Output 1 Cycle Time **0.00** parameter. Select the desired cycle time according to the output device used. If unsure, refer to the ordering code on page 52 of the instruction manual and compare it to the number on the label.

Recommended cycle times are:

For Control Output Device —	Select Cycle Time (in seconds)
B	15 to 120
E	0.2
F	0.2
G	0.2
S	0.2
T	15 to 120
Y	15 to 120

**IMPORTANT:** IF ONLY ONE OUTPUT IS **PID**, SET THE OTHER OUTPUT TO EITHER **ON/OFF**, **ALARM**, OR **OFF**.

- Press the **≡** key to display the next output parameter, and select the desired value using the **▲** or **▼** keys.
- Press **≡** to select other Output Type following steps 4 to 6.
- Press the **↻** repeatedly until **Auto** is displayed, then press **≡** and make sure autotune damping parameter is set to the proper setting for your application. See page 37 for more information.
- Press and hold **↻** key for approximately 3 seconds until upper display flashes **Auto** and Process Value.
- Press the **▲** or **▼** keys adjust setpoint to desired value.
- Press and hold **≡** key for 3 seconds. Lower display will indicate **Auto**. Press **▲** or **▼** key until **Auto** is displayed. Press **≡** to initiate autotuning. Display will flash **Auto**. After autotune is complete, the display stops flashing, and the controller will revert to Process Value display and begin controlling the process.
- If unacceptable overshoot occurs, change damping setting to high **Hi**, or if response is sluggish, change damping setting to low **Lo**.

## Notes

---



---



---



---



---



---



---



---



---



---



---



---



---



---



---



---



---



---



---



---



---



---

## Quick Setup Instructions - Series 18C/25C Temperature Controller

Experienced users, already familiar with the Series 18C/25C, and using the controller with PID outputs, may follow these condensed instructions to autotune the controller and get started quickly once the instrument is properly mounted and wired, and the Security Level is set to **Level 9**. Once setup is complete, we recommend changing the Security Level back to the most restrictive level suitable for your application.

These quick setup instructions are not meant as a substitute for reading the full instruction manual supplied with the controller. Please be sure to read through the manual for specific details of operation and, most importantly, for safety precautions. If you have any questions, or experience problems with setting up your controller, consult the full instruction manual first and, if you still need assistance, contact your Athena representative or call 1-800-782-6776.



Menu Access



Raise



Lower



Mode/Enter

1. Apply power. After self-check display stops, place controller in Standby mode by pressing and holding the Mode/Enter **≡** key for 3 seconds, the **▲** or **▼** key until **StdB** appears and then the **≡** key again. **StdB** will flash, alternating with the Process Value.
2. Press and hold the Menu Access **↻** key for 3 seconds until **LnP** is displayed. Press **≡** key once until **SPB** appears, then use **▲** or **▼** keys to select sensor input type.
3. Press **↻** to display **SPB**. Then press **≡** once to display **SPB**. Use **▲** or **▼** to select **PIA**.
4. Press the **≡** key until Output 1 Action **OLA** is displayed. Select the desired output action using the **▲** or **▼** keys. (Reverse = Heating)

5. Press **≡** again to display the Output 1 Cycle Time **OLA** parameter. Select the desired cycle time according to the output device used. If unsure, refer to the ordering code on page 52 of the instruction manual and compare it to the number on the label.

Recommended cycle times are:

For Control Output Device —	Select Cycle Time (in seconds)
B	15 to 120
E	0.2
F	0.2
G	0.2
S	0.2
T	15 to 120
Y	15 to 120

**IMPORTANT:** IF ONLY ONE OUTPUT IS **PID**, SET THE OTHER OUTPUT TO EITHER **ON/OFF**, **ALARM**, OR **OFF**.

6. Press the **≡** key to display the next output parameter, and select the desired value using the **▲** or **▼** keys.
7. Press **≡** to select other Output Type following steps 4 to 6.
8. Press the **↻** repeatedly until **LnP** is displayed, then press **≡** and make sure autotune damping parameter is set to the proper setting for your application. See page 37 for more information.
9. Press and hold **↻** key for approximately 3 seconds until upper display flashes **StdB** and Process Value.
10. Press the **▲** or **▼** keys adjust setpoint to desired value.
11. Press and hold **≡** key for 3 seconds. Lower display will indicate **StdB**. Press **▲** or **▼** key until **PLen** is displayed. Press **≡** to initiate autotuning. Display will flash **LnP**. After autotune is complete, the display stops flashing, and the controller will revert to Process Value display and begin controlling the process.
12. If unacceptable overshoot occurs, change damping setting to high **PL**, or if response is sluggish, change damping setting to low **LD**.

*For Technical Assistance in the U.S.,  
Call Toll Free: 1-800-782-6776*



**CORPORATE HEADQUARTERS**

Athena Controls, Inc.  
5145 Campus Drive  
Plymouth Meeting, PA 19462 U.S.A.  
Tel: (610) 828-2490  
Fax: (610) 828-7084  
Toll-Free in U.S.: 1-800-782-6776  
Internet: [www.athenacontrols.com](http://www.athenacontrols.com)

**EUROPE**

Athena Controls, Ltd.  
Capitol Business Centre  
60 Bramhall Lane South  
Bramhall, Stockport  
Cheshire, SK7 2DU, England  
Tel: +44 (0) 161 440 2522  
Fax: +44 (0) 161 440 9322  
E-mail: [AthenaUK@aol.com](mailto:AthenaUK@aol.com)

**INDIA**

Athena Controls (India) Pvt. Ltd.  
Ambli-Bopal Road  
Ahmedabad  
India 380058  
Tel: 91-2717-31120  
Fax: 91-79-6423570